

DELTA KLEPBESLAG

De multifunctionele Delta klepsteun is toe te passen bij op- en neergaande kleppen en deuren.
De Delta is zowel links als rechts te monteren door middel van de los meegeleverde bevestigingspunten.
De scharnierzijde omstelklip (A) bevindt zich onder het scharnierpunt.
De remkracht is in te stellen door middel van de inbus schroef (B) in het hart van het scharnierpunt.
Door de remkracht te verstellen blijven kleppen en deuren in iedere gewenste stand openstaan.

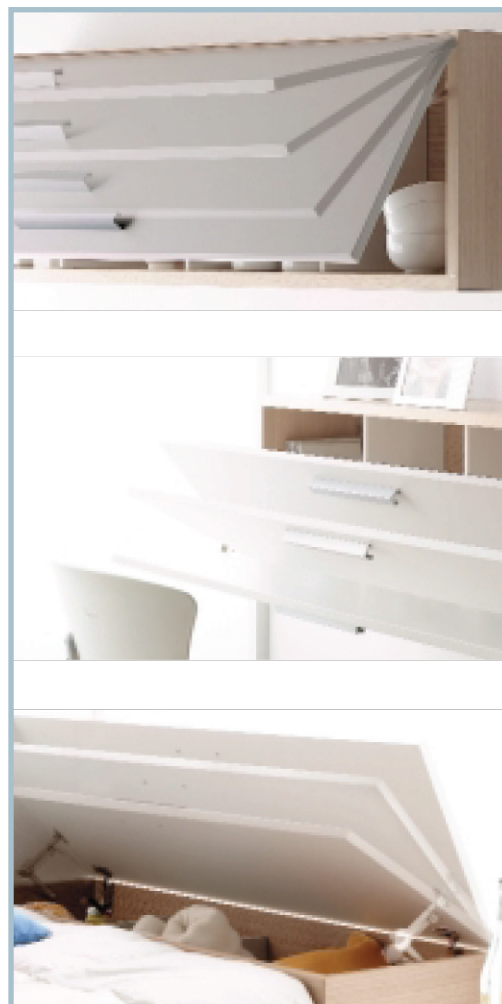

Artikel	Omschrijving	VE
3173085	Delta klepsteun	1

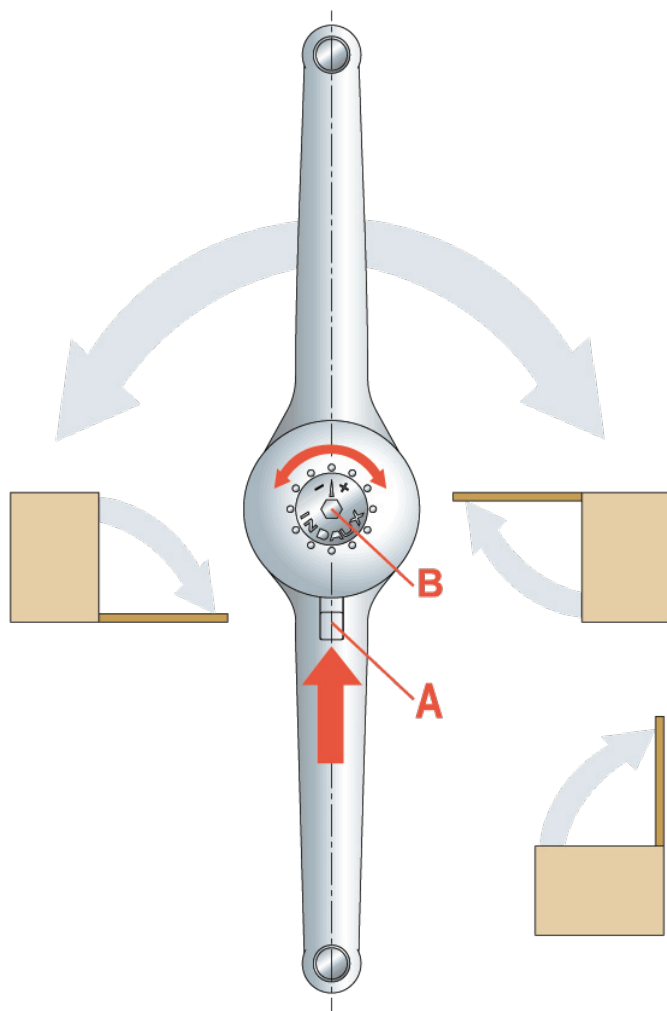
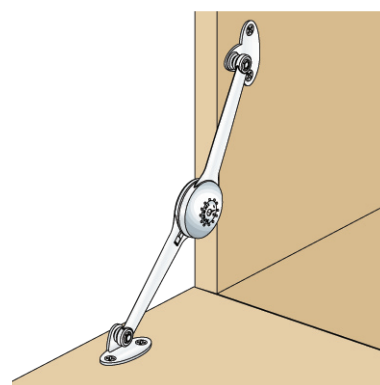
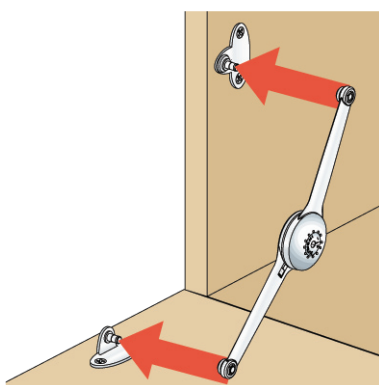
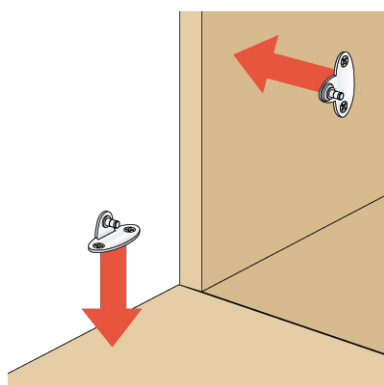

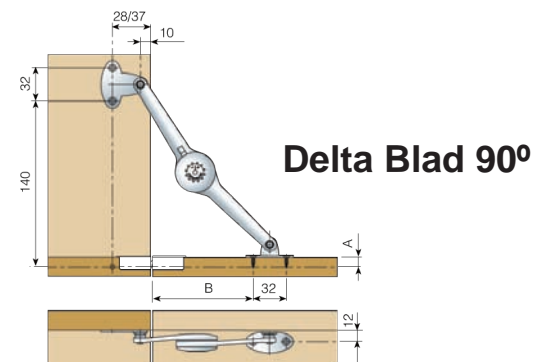
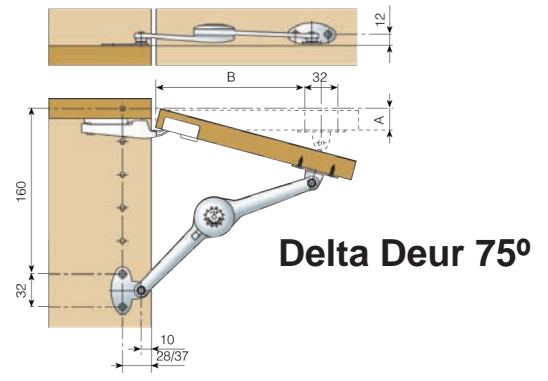
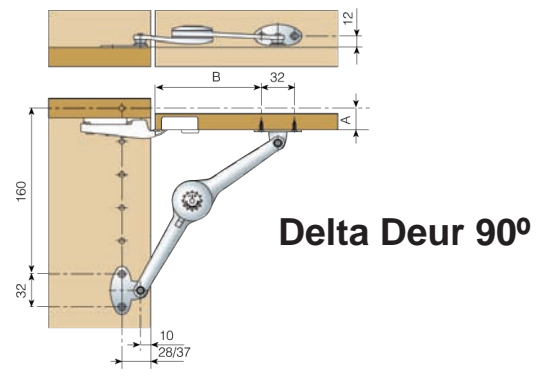
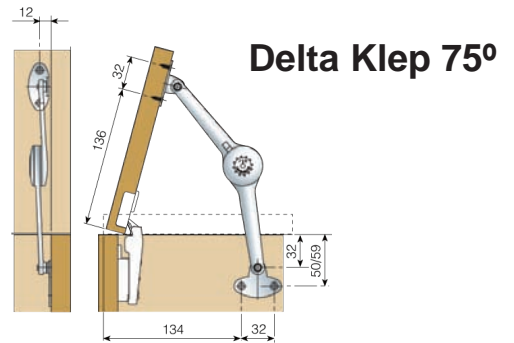
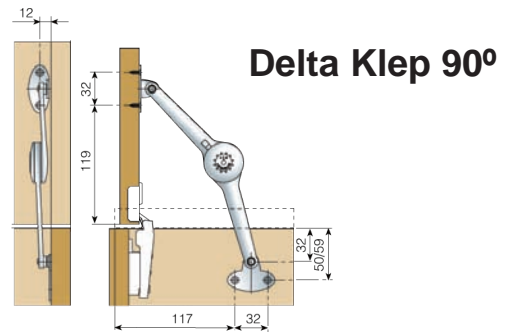
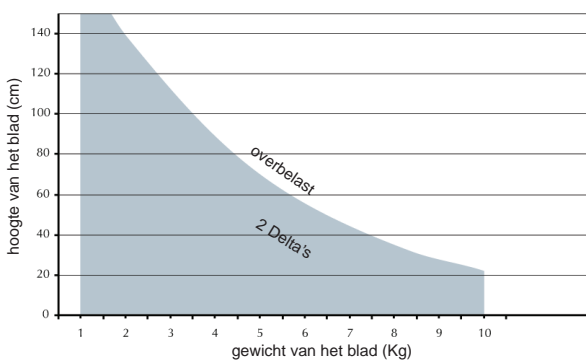
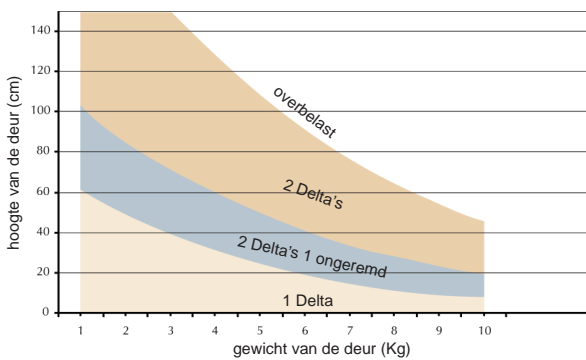
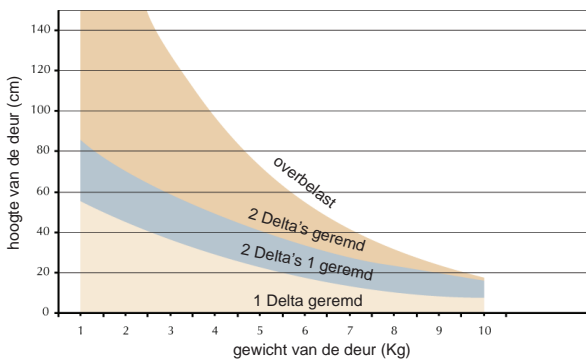
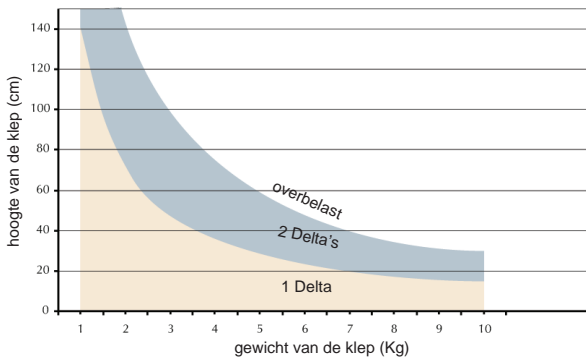
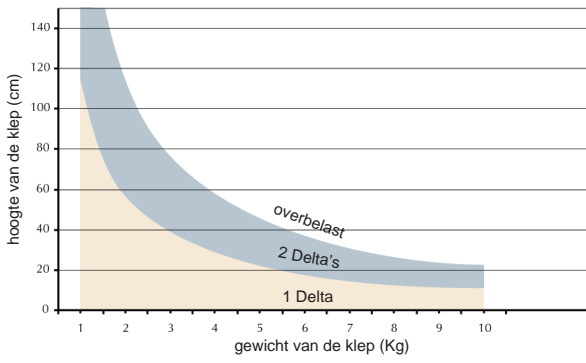

A	B
8	90
9	91
10	92
11	93
12	95
13	96
14	96
15	97
16	98
17	99
18	100
19	101
20	102
21	103
22	103
23	105
24	105
25	106

A	B
8	132
9	133
10	134
11	135
12	137
13	138
14	139
15	140
16	141
17	142
18	143
19	143
20	144
21	144
22	145
23	146
24	146
25	147

A	B
8	98
9	99
10	100
11	101
12	103
13	104
14	105
15	106
16	107
17	108
18	109
19	110
20	111
21	111
22	112
23	113
24	113
25	114